

Shipboard Electric Water Heater

80-5000 Gallon Capacity
15-1600 KW – All Voltages & Phases



The MSH is a storage packaged water heater for marine use.

Reliable

- Only high grade materials used in construction to ensure long operating life
- Hydrastone cement lining provides superior protection and tank longevity
- Heavy duty construction withstands demanding marine use

Marine Approvals

- United States Coast Guard (USCG) conformance and Type Approved by American Bureau of Shipping (ABS)
- USCG conformance and ABS Type Approval eliminates costly delays and uncertainties during ship inspection

Mounting Systems

- Heavy-duty legs secure the tank to deck
- Side-sway bulkhead attachment points provide added mounting stability
- The entire mounting system is integrally welded to tank for maximum stability and safety

Packaged System

- Fully packaged water heater saves time and money during installation
- All electrical operating controls are factory selected and wired to ensure reliable operation
- Full range of styles, sizes, and optional features to meet your exact water heating needs

A Heavy Duty Storage Electric Water Heater For Marine Use

The Hubbell Model MSH and MH water heater is specifically designed for marine use on board a surface vessel or platform and is in USCG conformance and is ABS Type Approved. By utilizing deck and bulkhead mounting supports, the water heater is securely fastened to the ship structure, thus providing a secure and reliable water heater installation. The heavy-duty carbon steel storage tank is lined with specially formulated hydrastone cement that provides superior protection, tank longevity and withstands demanding marine use.

When you specify and install a Hubbell model MSH or MH, knowing that it is in conformance with USCG regulations and is ABS Type Approved, you will have confidence that the ship owner will be provided with a quality product that is a long lasting and trouble free source for hot water.



ISO 9001:2008



Hubbell™ The Electric Heater Company

P.O. Box 288 ■ Stratford, CT 06615-0288

Phone: 203-378-2659 ■ FAX: 203-378-3593

E-mail: info@hubbellheaters.com ■ www.hubbellheaters.com

Cement Lined Tanks Provide Longer Service Life

Hubbell™

Q

What is the most common reason why a water heater fails?

A

Failure of a tank's protective lining allows water to come into direct contact with the steel tank causing it to corrode and leak.

Therefore, the type of protective lining is the single most important feature when determining the quality of any water heater. The ability of a lining to protect the steel tank is primarily based upon its thickness and complete coverage of all steel surfaces.

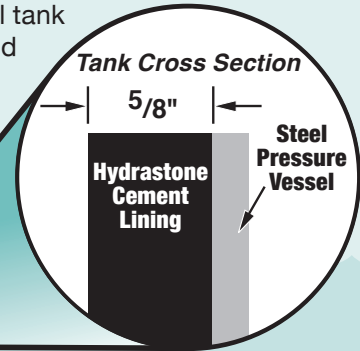
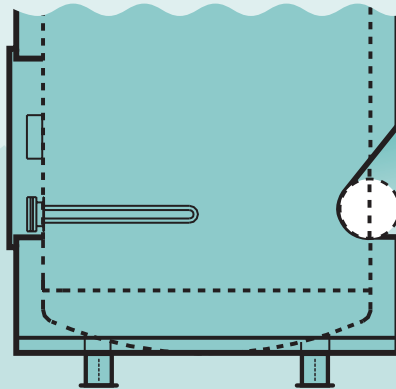

Linings Available For A Steel Tank

Cement Lining

A specially formulated Hydrastone cement applied to a minimum of 5/8" thickness on all surfaces. The cement lining covers 100% of all interior surfaces and is 125 times thicker than glass lining. Due to the thickness and guaranteed coverage of cement lining there is no need for a sacrificial anode. An extremely durable and long lasting lining suitable for hot and cold potable water storage in marine applications.

Phenolic Lining

An epoxy coating applied in 2 coats to a total of 10-12 mils DFT. Typically used in process applications using low conductivity DI, distilled or food grade water.

Non-Ferrous Tanks

A solid Non-Ferrous tank does not require a lining because the pressure vessel itself is constructed from material which is impervious to the corrosive effects of hot water. This type of tank will provide a significantly longer service life than all lined steel tanks, but is initially more costly.

90/10 Copper-Nickel

A 90% Copper 10% Nickel alloy provides excellent strength and corrosion resistance. Typically used in applications with corrosive environments (salt water) or in critical marine applications requiring long tank life.

Stainless Steel

Stainless Steel (Specify: Type 304, 316, or 316L) is suited for applications requiring a corrosion resistant tank with minimal leaching of impurities into the water. Well suited for process, RO and DI water systems.

Note: Unlined non-ferrous tanks do not require a manway. Inspection openings will be provided as required.



Model MSH and MH Standard Equipment

Vessel Construction

1. All welded carbon steel vessel designed and built in strict accordance with the ASME Code Section IV and stamped, certified and registered with the National Board of Boiler and Pressure Vessel Inspectors.
2. All internal tank surfaces are lined with a minimum of 5/8" thick Hydrastone cement for superior protection and tank longevity.
3. Designed for 100 psi working pressure and hydrostatically tested at 150 psi (1 1/2 times the WP).

General

1. Heavy duty 2" thick fiberglass blanket insulation covers the pressure vessel for maximum operating efficiency and minimal standby heat loss.
2. Heavy gauge galvanized steel protective jacket holds insulation in place and protected to ensure highly efficient operation.
3. Integrally welded bulkhead attachment points.
4. Entire vessel is supported on heavy duty integrally welded steel supports for sturdy deck mounting.
5. Full five (5) year Non Pro-Rated tank warranty and one (1) year electrical component warranty.
6. Bronze ASME rated combination temperature and pressure safety relief valve set at the vessel working pressure and 210°F.
7. ABS Type Approved and in conformance with USCG regulations.

Electrical Operating Controls

1. All electrical operating controls are factory sized, selected, wired, tested, and mounted in a NEMA 1 enclosure to ensure safe and reliable operation.
2. A power distribution block is supplied for single point electrical installation.
3. Power fuses rated at a maximum of 60 Amps protect each heating element branch circuit per NEC and UL requirements. Each branch circuit has a maximum rating of 48 Amps.
4. Heavy duty definite purpose magnetic contactor with integrally mounted power fuse block assembly switches power on/off to each branch circuit.
5. Heavy duty removable flange type immersion heating element provides long service life.
6. Fully adjustable thermostat maintains accurate water temperature and is sized by the factory to control the appropriate number of heating element circuits.
7. A generously sized transformer provides fused 120V to the control circuit
8. A fully adjustable (100-240 °F) safety hi-limit device with manual reset interrupts power to the control circuit in the event of over-temperature water in the storage tank.
9. Safety door interlock mechanism interrupts power to the control circuit upon opening the electrical control panel.
10. Louvers in the control panel allow for cooling of the electrical components to ensure maximum electrical component longevity (when required).

Model MSH and MH Optional Equipment

Vessel

- 1A. **Alternate protective lining:**
Phenolic epoxy resin.
- 1B. **Alternate vessel construction:**
Stainless Steel (Please specify Type: 304, 316 or 316L)
90/10 Copper-Nickel, other.
- 1C. **Alternate working pressure:**
Please specify
- 1D. **Alternate tank design:**
ASME stamped to Section I or VIII

General

- 1. Skid mounting on heavy duty all welded I Beam
- 2. Type 304 stainless steel protective jacket, please specify if painted.
- 3. Dual energy package provides operational flexibility for electric and steam or boiler water power. See page 8 for details.
- 4. Manway 12" x 16" size
- 5. Inspection opening 3" NPT
- 6. Specific third party approval including BV, NR-13, Lloyds or MIL spec.

Electrical

- 1. NEMA 4 weather resistant enclosure for outdoor/wet locations.
- 2. Explosion resistant enclosure for hazardous locations. Please specify class, division, and group.
- 3. Built-in circuit breaker (with or without shunt trip) or a built-in non-fused On/Off disconnect switch.
- 4. Alternate element sheath material (Please specify: Incoloy, Stainless Steel, other).
- 5. Specialized heating element construction including: Special watt density rating, passivation, electropolishing, hermetic seals or any other feature required to meet the needs of your application.
- 6. Factory installed low water cut out device to disengage electrically the heating element(s) in the event of insufficient water in the tank.
- 7. Dial thermometer and pressure gauge factory installed in the tank.
- 8. Intra-tank circulation pump package with On/Off switch to continuously circulate water within the tank and thereby reduce stratification.
- 9. Status indicating lamp(s).
- 10. Audible alarm system.
- 11. Digital display electronic temperature controller. Please specify with or without RS485 communication port for remote operation of the temperature controller.
- 12. Additional ground connections

**Outline Dimensions
Model MSH (vertical)**

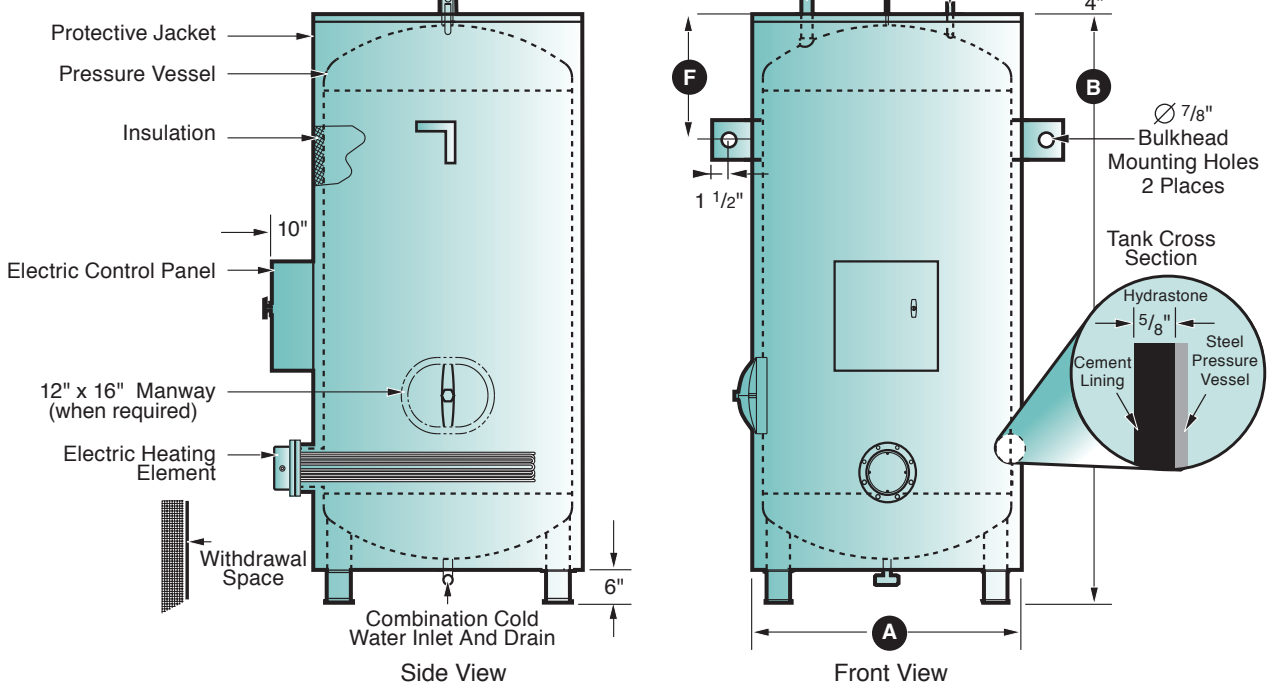
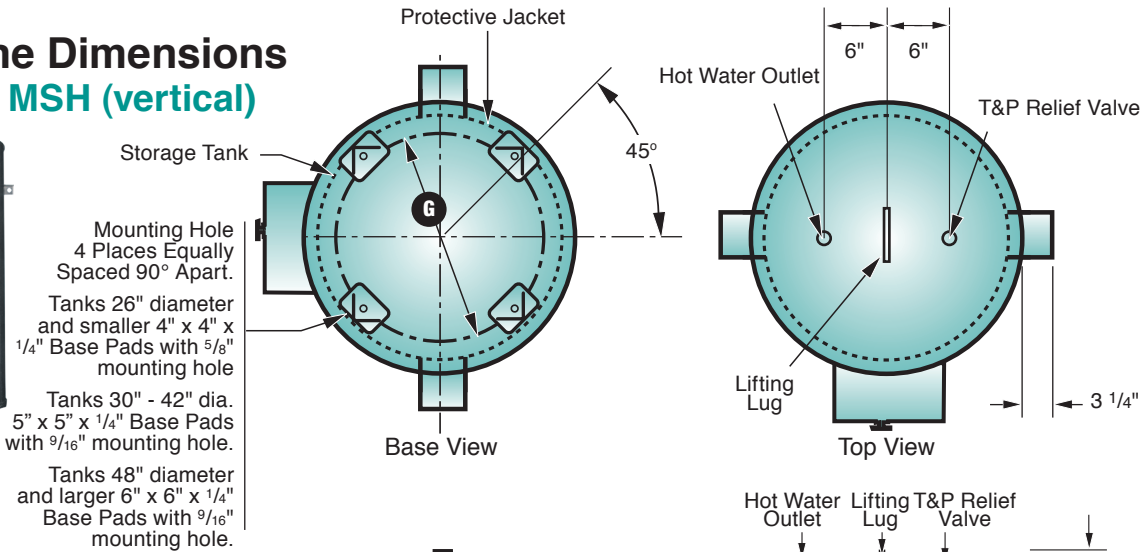

Model MH (horizontal)

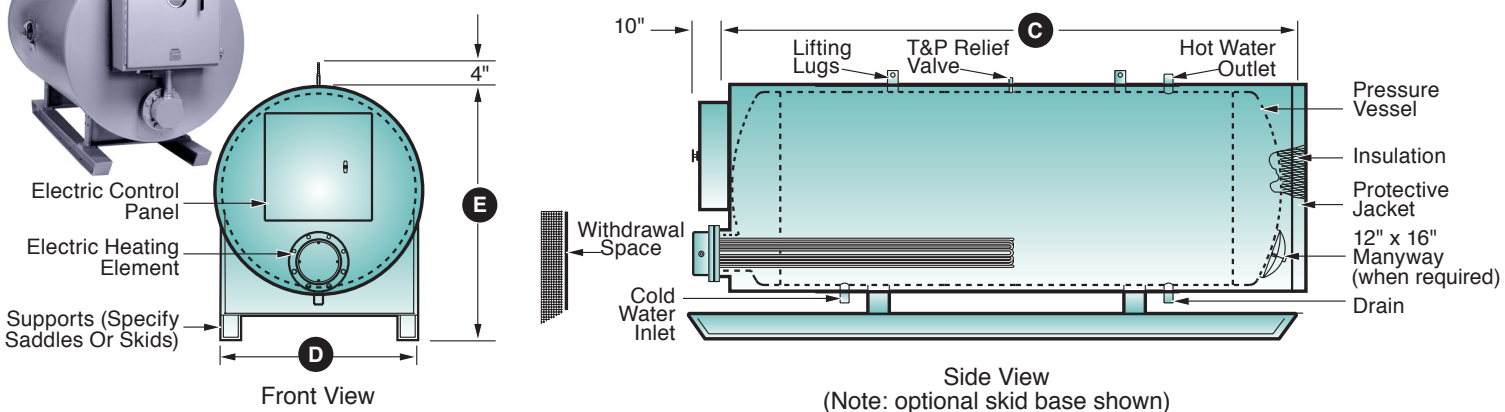



Dimensional Data, Model MSH & MH

Storage Capacity (Gallons)	Overall Dimensions (Inches)							Storage Tank Diameter x Length	Inlet Outlet Sizing (NPT)	Approx. Shipping Weight (Lbs.)
	Vertical		Length C	Width D	Height E	Bulkhead Mounting F	Bolt Circle G			
	Diameter A	Height B								
80	26	65	60	26	32	15	18	22 x 54	1½	1000
120	28	75	71	28	34	15	18	24 x 63	1½	1150
150	30	79	75	30	36	20	24	26 x 68	1½	1300
175	34	73	67	34	40	20	24	30 x 63	1½	1500
200	34	82	76	34	40	20	24	30 x 72	1½	1700
225	34	89	83	34	40	20	24	30 x 79	1½	1750
250	40	74	68	40	46	20	30	36 x 64	1½	1850
275	40	80	74	40	46	20	30	36 x 70	1½	2000
300	40	88	82	40	46	20	30	36 x 78	1½	2180
325	40	92	86	40	46	20	30	36 x 82	1½	2300
350	40	94	88	40	46	20	30	36 x 84	1½	2500
375	46	81	75	46	52	22	36	42 x 71	1½	2600
400	46	85	79	46	52	22	36	42 x 75	1½	2700
425	46	88	82	46	52	22	36	42 x 78	1½	2900
450	46	93	87	46	52	22	36	42 x 83	1½	3000
475	52	79	73	52	58	24	42	48 x 69	2	3100
500	52	82	76	52	58	24	42	48 x 72	2	3225
525	52	85	79	52	58	24	42	48 x 75	2	3350
550	52	89	83	52	58	24	42	48 x 79	2	3400
575	52	93	87	52	58	24	42	48 x 83	2	3500
600	52	95	89	52	58	24	42	48 x 85	2	3650
700	52	107	101	52	58	24	42	48 x 97	2	4000
800	52	119	113	52	58	24	42	48 x 109	2	4300
900	52	132	126	52	58	24	42	48 x 122	2	4800
1000	52	145	139	52	58	24	42	48 x 135	2	5200
1250	58	149	143	58	64	26	48	54 x 139	2	5600
1500	58	174	168	58	64	26	48	54 x 164	2	6000
1750	64	168	162	64	70	28	54	60 x 158	3	7400
2000	64	185	179	64	70	28	54	60 x 175	3	8100
2500	76	169	163	76	82	32	60	72 x 159	3	8200
3000	76	197	191	76	82	32	60	72 x 187	3	8300
3500	88	174	168	88	94	36	72	84 x 164	6 FLG.	8900
4000	88	195	189	88	94	36	72	84 x 185	6 FLG.	9800
4500	N/A	N/A	178	94	100	40	84	90 x 174	6 FLG.	10700
5000	N/A	N/A	200	94	100	40	84	90 x 196	6 FLG.	11600

Note: All dimensions are approximate and subject to change. Please reference the submittal drawing for actual dimensions. The tank selections above are shown for convenience. A full selection of storage capacities are available by entering the desired capacity into the model number.

* 80, 120 and 150 gallon tanks do not come equipped with a manway. Please consult factory if desired on these sizes.



Recovery Ratings And Amperage At Selected KW

KW INPUT	BTU/HR RATING	Gallons Per Hour (GPH) Heated At Various Temperature Rises					Amperage Rating At Various Voltages				
		60 °F Δ	80 °F Δ	100 °F Δ	120 °F Δ	140 °F Δ	208V 3F	240V 3F	380V 3F	440V 3F	480V 3F
15	51,195	103	77	62	51	44	42	36	23	21	18
20	68,260	137	103	82	68	59	56	48	30	28	24
25	85,325	171	128	103	85	73	69	60	38	35	30
30	102,390	205	154	123	103	88	83	72	46	42	36
35	119,455	239	179	144	120	103	97	84	53	49	42
40	136,520	273	205	164	137	117	111	96	61	56	48
45	153,585	308	231	185	154	132	125	108	68	63	54
50	170,650	342	256	205	171	146	139	120	76	70	60
55	187,715	376	282	226	188	161	153	132	84	77	66
60	204,780	410	308	246	205	176	167	145	91	84	72
65	221,845	444	333	267	222	190	181	157	99	91	78
70	238,910	478	359	287	239	205	195	169	106	97	84
75	255,975	513	384	308	256	220	208	181	114	104	90
80	273,040	547	410	328	273	234	222	193	122	111	96
85	290,105	581	436	349	290	249	236	205	129	118	102
90	307,170	615	461	369	308	264	250	217	137	125	108
95	324,235	649	487	390	325	278	264	229	145	132	114
100	341,300	683	513	410	342	293	278	241	152	139	120
110	375,430	752	564	451	376	322	306	265	167	153	132
120	409,560	820	615	492	410	351	333	289	183	167	145
125	426,625	854	641	513	427	366	347	301	190	174	151
150	511,950	1025	769	615	513	439	417	361	228	209	181
175	597,275	1196	897	718	598	513	486	421	266	244	211
200	682,600	1367	1025	820	683	586	556	482	304	279	241
225	767,925	1538	1153	923	769	659	625	542	342	313	271
250	853,250	1708	1281	1025	854	732	695	602	380	348	301
275	938,575	1879	1409	1128	940	805	764	662	418	383	331
300	1,023,900	2050	1538	1230	1025	879	834	723	456	418	361
325	1,109,225	2221	1666	1333	1110	952	903	783	494	453	391
350	1,194,550	2392	1794	1435	1196	1025	973	843	532	487	421
375	1,279,875	2563	1922	1538	1281	1098	1042	903	570	522	452
400	1,365,200	2733	2050	1640	1367	1171	1112	963	608	557	482
450	1,535,850	3075	2306	1845	1538	1318	1251	1084	685	627	542
500	1,706,500	3417	2563	2050	1708	1464	1390	1204	761	696	602
1000	3,412,000	6833	5125	4100	3417	2929	2779	2408	1521	1393	1204
1200	4,094,400	8200	6150	4920	4100	3514	3335	2890	1825	1671	1445
1400	4,776,800	9567	7175	5740	4783	4100	3891	3372	2130	1950	1686
1600	5,459,200	10933	8200	6560	5467	4686	4446	3854	2434	2229	1927

Notes: The KW selections above are shown for convenience. A full selection of KW ratings from 1 to 1600 KW is available by entering the desired KW into the model number. For alternate voltages including 415, 575 and 600 volt, please consult factory.

Electrical

$$\frac{\text{KW} \times 1000}{\text{Volts}} \div 1.73 = \text{Amps } 3 \Phi$$

$$\frac{\text{KW} \times 1000}{\text{Volts}} = \text{Amps } 1 \Phi$$

Example: 150 KW at 480V 3Φ

$$\frac{150 \times 1000}{480} \div 1.73 = 180 \text{ Total Amp Draw}$$

180 ÷ 48 Amps max circuit rating = 3.75
Round up the number of circuits to 4

Note: Each branch circuit is rated at a maximum of 48 Amps and each circuit is typically operated as an independent temperature step.



Model MSH & MH Sizing Information

Step 1: Solve for the unknown using the formulas stated below

Variables To Solve For:

KW Requirement: _____ GPH x _____ °F ΔT x 0.00244 = _____ KW

Temperature Rise: _____ KW x 410 ÷ _____ GPH = _____ °F ΔT

Flow Rate: _____ KW x 410 ÷ _____ °F ΔT = _____ GPH

Metric Conversions

Liters x 0.2641 = Gallons	°C = (°F - 32) x 0.556	psi x 6.86 = kPa
Gallons x 3.79 = Liters	Watts/Sq.Cm. x 6.4 = Watts/Sq.In.	kPa x 0.1456 = psi
Gallons x 0.003785 = m³	Watts/Sq.In. x 0.155 = Watts/Sq.Cm.	Kg/cm² x 14.28 = psi
m³ x 264.2 = Gallons	psi x 0.06896 = Bar	psi x 0.07 = Kg/cm²
1°C ΔT = 1.8°F ΔT	Bar x 14.5 = psi	Lbs x 0.4536 = Kg
°F = (°C x 1.8) + 32		Kg x 2.2 = Lbs

Model Number Designation

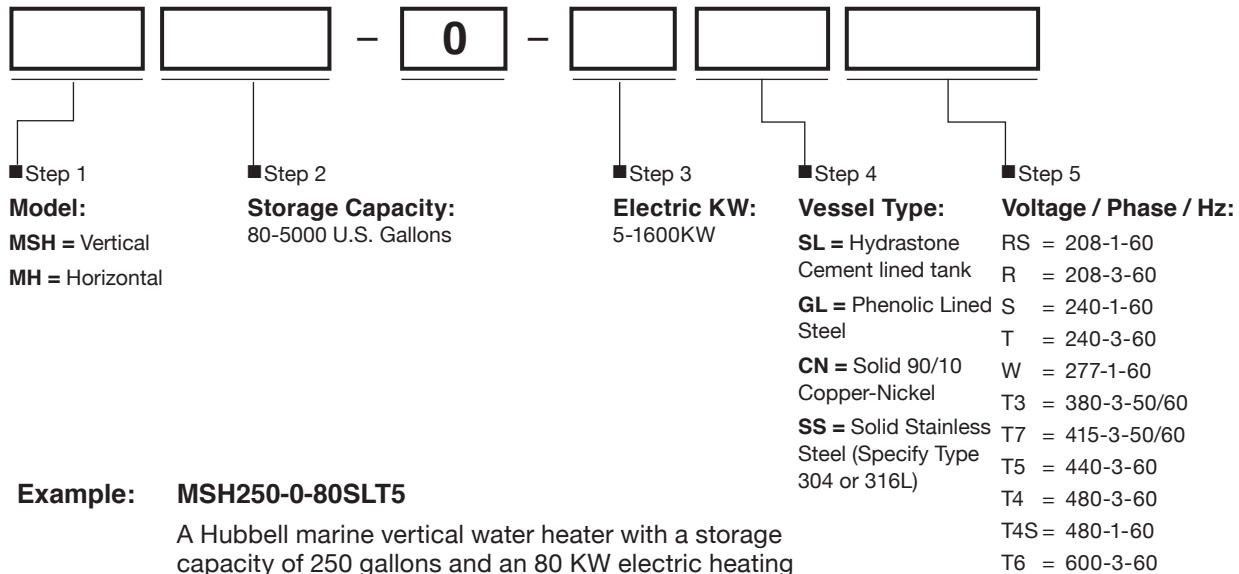

Example: **MSH250-0-80SLT5**
 A Hubbell marine vertical water heater with a storage capacity of 250 gallons and an 80 KW electric heating element. The tank is cement lined. Power required is 440 VAC, 3 phase, 60 Hz.

Option Note

Any and all optional equipment for a water heater must be called out in the written specification. A model number in and of itself does not reflect any optional equipment selected.

(Manufacturer reserves the right to change specifications without notice.)

Benefit Of Dual Fuel Capability

The Hubbell model MSH and MH water heater is available with a factory installed heat exchanger to provide heating capability utilizing ships steam or boiler water. While the ship is under way and the boilers are producing steam, the water heater will operate in “primary” mode and use steam to heat the water. When the ship is dockside, and steam generation is reduced (or completely shut down), the operator can switch the water heater over to electric heating mode by simply turning a switch on the Hubbell control panel which activates the factory packaged and installed electric immersion heaters. This dual fuel capability provides ship operators with complete flexibility in determining which fuel mode is most advantageous to operate at any given time.

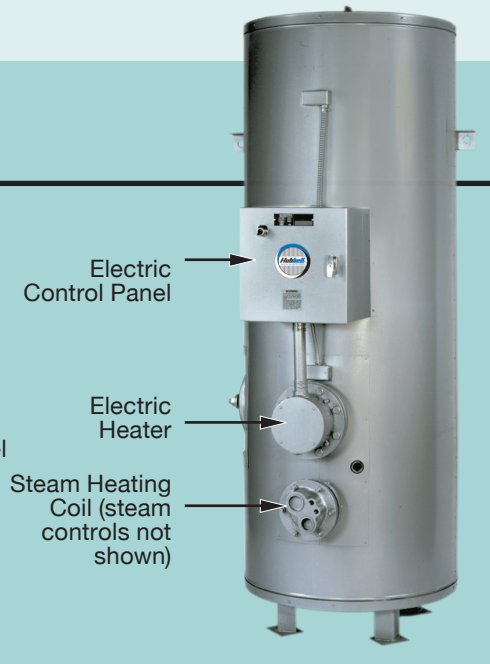

Standard Features

Steam / Boiler Water Heating Coil

1. A high quality factory installed 2 pass U-Tube heating coil constructed from 18 BWG 3/4" O.D. single wall copper tubing designed for a maximum working pressure of 150 psi.
2. All wetted parts including the tube sheet and baffles are non-ferrous for maximum longevity.
3. Heavy duty fabricated steel head with threaded NPT steam and condensate connections.

Steam Operating Controls

1. Steam operating controls are factory selected, sized, piped and tested to ensure reliable operation.
2. All steam components are factory plumbed with schedule 40 black iron pipe and ready for steam and condensate connections.
3. High quality cast iron pilot operated steam control valve modulates the flow of steam through the heating coil to provide accurate water temperature control.
4. Cast iron Y strainer with 20 Mesh screen protects the steam controls and coil from dirt and debris in the steam supply.
5. Thermostatic drip trap removes condensate from the steam supply line.
6. Heavy duty cast iron float and thermostatic main condensate trap for optimum efficiency.
7. Brass vacuum breaker and dial steam pressure gauge installed in the heating coil head.

Note: Additional steam and boiler water design literature is available in Hubbell brochures titled “ST”, “BW” and “Heating Coils”.

Optional Features

Optional vessel construction and optional general construction features as shown on page 3.

Steam Heating Coil

- 1. Double wall tubing with a leak detection port
- 2. **Alternate tubing material please specify:** (Stainless Steel, 90/10 Copper-Nickel, Other)
- 3. **Fabricated steam head constructed from:** (Stainless Steel, Copper Alloy, Other)

Operating Controls

- 4. Steam controls are factory selected and sized, but shipped loose for in the field installation by others.
- 5. Various steam control valves are available to meet the specific needs of your application, please specify: Self-operated type, pneumatic operated, electric motor operated, separate pressure reducing pilot type.
- 6. Single solenoid safety system closes the control valve should the water temperature in the tank reach the hi-limit set point. Requires 120 volt 5 amp electrical service.
- 7. A double solenoid safety system dumps over heated water in the storage tank to drain in addition to closing the control valve. Requires 120 volt 5 amp electrical service.
- 8. Dial water thermometer and pressure gauge factory installed in the tank.
- 9. Factory wrapped and baffled steam coil with integral pump package.
- 10. Steam Controls to be cast steel construction.



Optional Steam Package

Shipboard Electric Water Heater

Steam Component General Configuration

The steam control valve maintains accurate water temperature in a steam fired water heater by regulating the flow of steam through the heating coil.

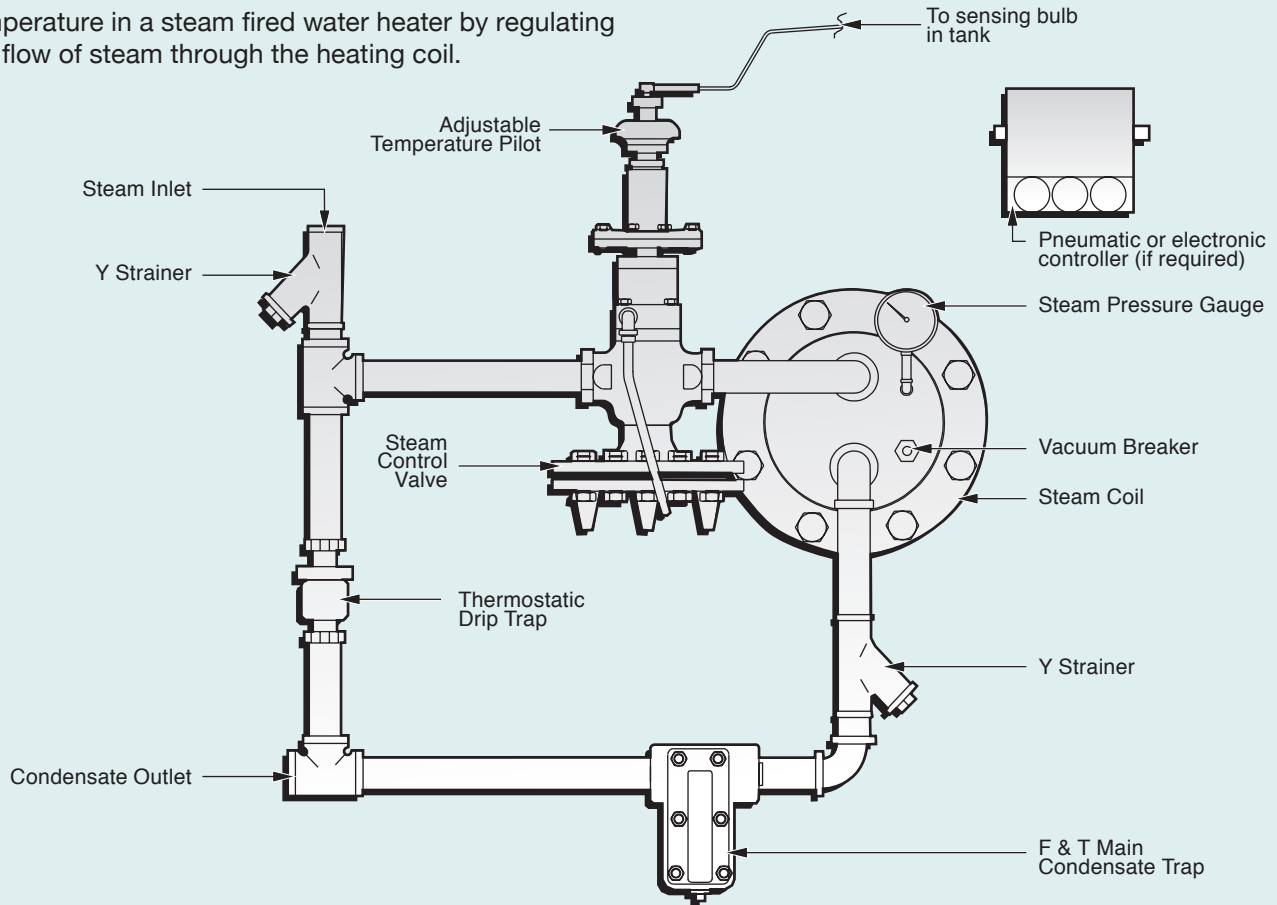

There are four types of steam control valves available for use on a steam fired storage water heater.

Self Operating

The valve design includes a bulb and capillary assembly charged with a thermally responsive vapor. The expansion/contraction of the vapor acts upon the valve bellows in order to control the flow of steam through the valve. No external power source is required for operation.

Pneumatically Operated

In this configuration the ship's air supply feeds a factory installed temperature controller which operates the steam control valve. The temperature controller sends a precise air signal to the steam control valve which adjusts the flow of steam into the heating coil. The temperature controller is fully adjustable from 50-250°F and requires 20 psi air at a maximum consumption of 0.5 SCFM.

Pilot Operated

A pilot operated control valve is the most widely used type of valve for standard water heating applications. In this type of valve, a temperature pilot device utilizes steam to operate the main valve. No external power source is required other than steam. This is a highly dependable temperature control system which is suitable for most applications. As an option, this valve may include a pressure reducing pilot which limits the steam pressure to a predetermined maximum.

Electronic Operated

This control valve is similar to a pneumatically operated system, except in this case the temperature controller is a sophisticated digital display electronic device which outputs a 4-20ma signal to a compact motor mounted on the steam control valve in order to proportionally control the flow of steam to the heating coil. The temperature controller displays set point as well as actual water temperature and is available with an RS485 communications port for remote control.

Heating Coil General Configuration

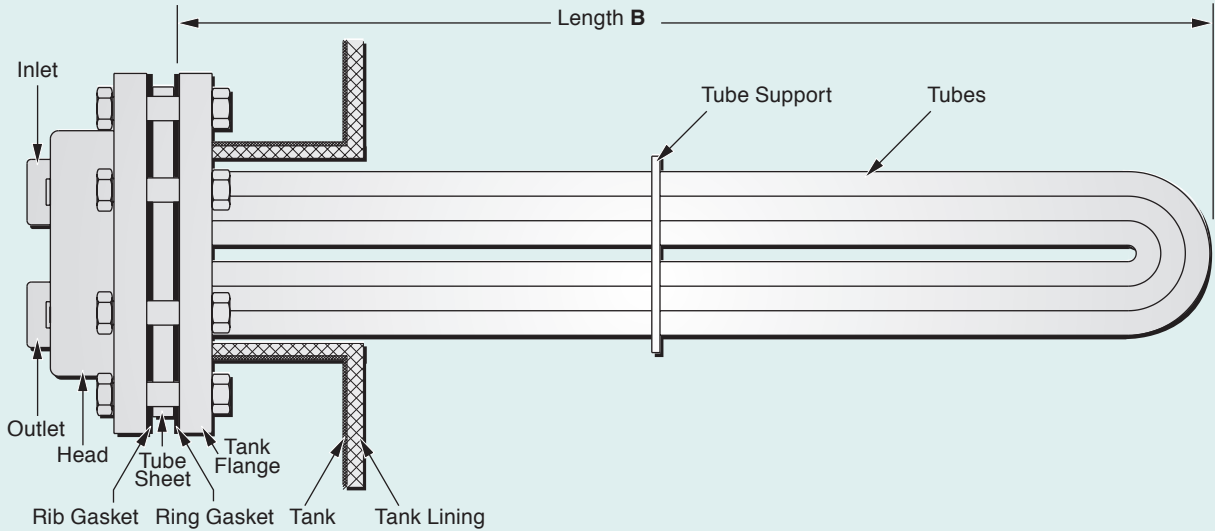

Please Complete The Following Information:

1 Tube Sheet Data

Outside Diameter _____

Thickness _____

Material _____

Number of Tube holes in the tube sheet _____

Does the tube sheet have Bolt Holes in it?
 Yes No

If Yes:

- # of bolt holes _____
- Dia. of bolt holes _____
- Bolt circle _____

Do the bolt holes straddle the centerline?
 Yes No

2 Diameter of the neck nozzle on the tank.

Outside Diameter _____

Inside Diameter _____
(Include thickness of neck lining, if any)

Circumference Of Neck _____

3 Immersion length of tubes "B" _____

Heating surface area in Sq. Ft. (if known) _____

Tank Type: Vertical Horizontal

Tank dimensions: Diameter _____

Height _____

Pull space maximum length _____

4 Tube Outside Diameter _____

Material _____

Gauge _____ BWG

Type Single Wall Double Wall

Design Pressure _____

Design Temperature _____

5 Number of passes _____

6 Number of tube supports _____

Full Half type

Distance to each tube support _____

Material _____

O.D. of supports _____

Thickness _____

7 Recovery rated to heat _____ GPH

from _____ °F to _____ °F

When supplied with the following heat source:

Steam at _____ psig

_____ Lbs./Hour

Steam Consumption

Boiler Water at _____ GPM

from _____ °F to _____ °F

HTHW at _____ GPM

from _____ °F to _____ °F

8 Pressure Drop

Steam _____ psi

Boiler or HTHW _____ psi



Optional Steam Package

Shipboard Electric Water Heater

Steam Consumption Formula

$$\frac{\text{[] GPH} \times \text{[] } ^\circ\text{F } \Delta\text{T} \times 8.33}{\text{[] Latent Heat of Steam}} = \text{[] Lbs / Hr Steam}$$

Steam Pressure (psi)	0	2	5	10	15	20	25	30	40	50
Latent Heat	970	966	960	953	946	939	933	929	920	912

Dual Fuel Model Number Designation

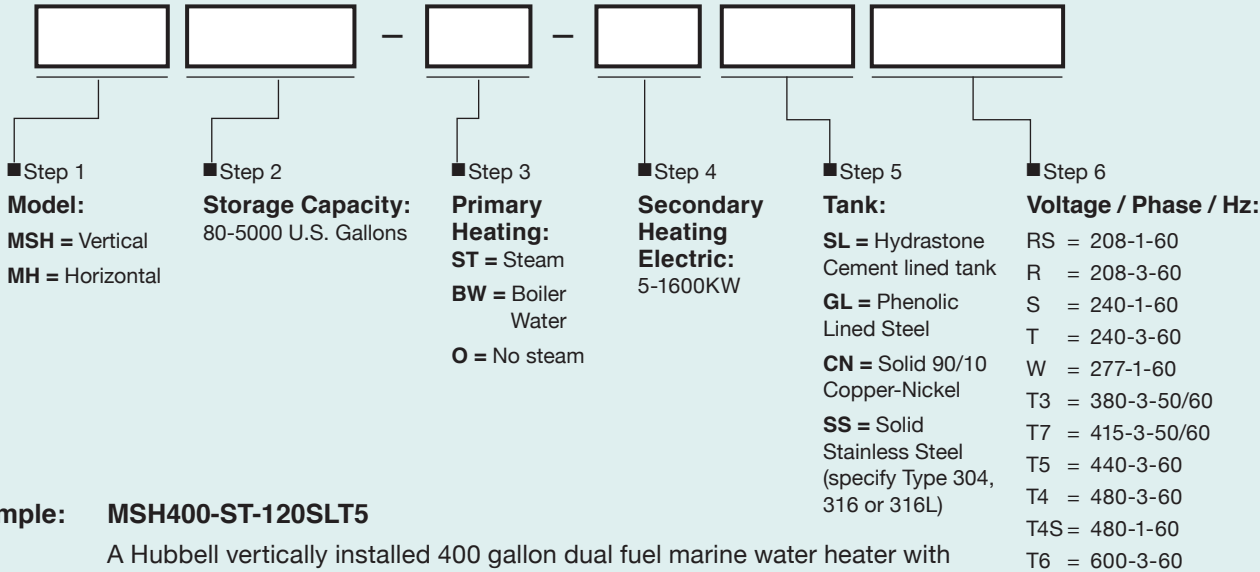

Example: MSH400-ST-120SLT5

A Hubbell vertically installed 400 gallon dual fuel marine water heater with a factory installed steam heating coil as the primary heating source and a 120 KW electric heating element to operate as the secondary heating source. Tank is cement lined. Power required is 440 VAC, 3 phase, 60 Hz. Please note that steam heating capacity and construction features are not identified in the model number and therefore must be noted in the written specifications.

Option Note

Any and all optional equipment for a water heater must be called out in the written specifications. A model number in and of itself does not reflect any optional equipment selected.
 (Manufacturer reserves the right to change specifications without notice.)



Model MSH & MH

Master Specification

SHIP NAME _____

ENGINEER / NAVAL ARCHITECT _____

SHIPYARD _____

CONTRACTOR / SHIP CHANDLER _____

General

Provide a quantity of _____ packaged type Marine Electric water heater(s) Model No. _____ as manufactured by HUBBELL The Electric Heater Co., Stratford, CT. The water heater shall be constructed specifically for shipboard installation by utilizing deck and bulkhead mounting supports that are integrally mounted to the pressure vessel. The pressure vessel section, including the electrical control panel, shall be mounted on structural supports and be suitably insulated, jacketed, painted and provided with lifting lugs. The entire unit is to be packaged ready for plumbing and electric service connections and shall bear the UL listing mark certifying the entire water heater. The water heater shall conform to USCG regulations per 46 CFR 53.01-10 and be ABS Type Approved.

Pressure Vessel

The pressure vessel shall be all welded construction and ASME Code Section IV stamped for a working pressure of 100 psi and contain a minimum of _____ gallons of storage. The storage vessel shall be carbon steel and lined with seamless Hydrastone cement applied to a minimum thickness of 5/8" on 100% of all interior tank surfaces, (**Optional Specifications:** *Phenolic lined steel tank, solid 90/10 copper-nickel tank, solid Type 304, 316 or 316L Stainless Steel Tank.*) The pressure vessel is to be covered with 2" thick fiberglass blanket insulation and enclosed in a heavy gauge galvanized steel metal jacket finished in gray hammertone enamel. The vessel shall be protected by an ASME approved automatic reseating combination temperature and pressure relief valve set at the tank working pressure and 210 °F.

Electric Recovery

The recovery section shall be rated at _____ KW which will heat _____ GPH of water at _____ °F rise (_____ °F to _____ °F).

Electric Controls

The heater shall be designed to operate at _____ volts, _____ phase, _____ HZ with a fused low voltage transformer providing 120 volt to all operating controls. The immersion heating element(s) shall be high quality copper sheathed (**Optional Specification:** *Incoloy, Type 304, 316 or 321 stainless steel*) and sized to obtain the rated recovery. Each element circuit is to be independently operated through a definite purpose magnetic contactor having a resistive load rating equal to or exceeding the ampere rating of that particular circuit and shall be protected by individual power fuses rated approximately 125% of the ampacity of the circuit. Multiple circuit elements shall be provided with a power distribution block for connecting of the incoming power feeds (**Optional Specifications:** *Built-in non-fused On/Off disconnect switch, built-in circuit breaker with an On/Off handle.*) A safety door interlock switch shall interrupt power to the control circuit when the control panel door is opened. The control thermostat shall be immersion type and shall be consistent with the recovery rate of the heating element as to the number of steps required. A hi-limit control with a manual reset button shall be factory installed to disconnect all ungrounded conductors to the heating element(s) in the event of an over-temperature condition in the storage section.

Option _____

Option _____

Option _____

Dual Fuel Package

- Shall be required
- Shall not be required

The heating coil shall utilize (**Optional Specification:** *steam, boiler water, HTHW*) and be rated to heat _____ GPH of water at a _____ °F rise (_____ °F to _____ °F) when supplied with _____ psi steam (boiler water) to the control valve and consume _____ lbs/hour steam. The heating coil shall be a fully removable immersion U-tube heating coil rated for 150 psi working pressure. The single wall (**Optional Specification:** *Double wall*) coil shall be constructed from 18 BWG 3/4" OD copper (**Optional Specification:** *90/10 Copper-nickel, stainless steel*) tubes. The coil including the tube sheet, baffles, and spacers shall have all non-ferrous wetted parts and a fabricated steel head. The water heater shall (shall not) be supplied with steam operating controls. A self-contained (**Optional Specification:** *Pneumatic, pilot, electric*) type steam control valve shall regulate the flow of steam to the heating coil in order to control water temperature. A drip trap, main condensate trap, Y strainers, vacuum breaker, and steam pressure gauge shall be factory sized and piped with the steam control valve.

In addition, the following steam options may be selected:

- Option:** The water heater shall be equipped with a factory-packaged intra-tank circulator to continuously circulate water within the tank to reduce stratification.
- Option:** The heating coil shall be wrapped and baffled and piped with an integral pump package to force circulate water over the heating coil in order to reduce the coil size.
- Option:** Single solenoid safety system to close the control valve should the water temperature in the tank reach the hi-limit set point. Requires 5 Amp, 120 Volt service.
- Option:** Double solenoid safety system dumps over heated water in the storage tank to drain in addition to closing the control valve. Requires 5 Amp, 120 Volt service.

Warranty

The water heater manufacturer shall warranty all components against defects in workmanship and material for a period of one (1) year from date of start up, and the pressure vessel for a full five (5) years Non Pro-Rated (**Optional Specification:** *full ten (10) years Non Pro-Rated tank warranty*) from start-up, provided that the unit is started within three (3) months of date of shipment and installed and operated within the scope of the tank design and operating capability. Each water heater shall be shipped with a complete set of installation and operating instructions including spare parts list and approved drawing.

ISO 9001:2008



Committed to continuous improvements

Continuing research results in product improvement; therefore these specifications are subject to change without notice. For the most updated information, consult the factory.



Marine Products Division

Made in the U.S.A.



The Electric Heater Company ■ P.O. Box 288 ■ Stratford, CT 06615-0288

Phone: 203-378-2659 ■ FAX: 203-378-3593 ■ info@hubbellheaters.com ■ www.hubbellheaters.com